



Hydraulic Earth Drills

OPERATORS MANUAL
WITH MAINTENANCE AND PARTS INFORMATION

1.800.227.7515
LITTLEBEAVER.COM



LITTLE BEAVER®
EARTH DRILLS & AUGERS

MFG BY: Little Beaver, Inc. 0318

P.O. Box 840, Livingston, Texas 77351
Phone: 936.327.3121 Fax: 936.327.4025
littlebeaver.com sales@littlebeaver.com

CUSTOMER SERVICE

Ph: 800/227-7515 or 936/327-3121 or Fax 936/327-4025

ORDERS...

Place your orders by telephone, fax, or mail. When calling, please have your parts manual handy for reference. Our hours are 8:00 am - 4:30 pm central time, Monday thru Friday. When ordering by mail or fax, include a description and LITTLE BEAVER part number for the items you are ordering, your return address, and payment or your authorization for COD shipment.

All orders are shipped UPS where possible. Freight charges will be added to your invoice. Some items are oversize, resulting in a higher shipping cost. Power units and larger augers are shipped via motor freight due to their weight.

PAYMENT TERMS...

COD, Cash in Advance, Visa, Mastercard or NET 30 with approved credit. COD limit for new accounts is \$500.00. Personal or company checks on new accounts will be held until they clear the bank. To eliminate this delay, you may pay by wire transfer or send a certified or cashiers check. For a NET 30 open account, please call or write for a credit application.

SERVICE AND REPAIR...

Your LITTLE BEAVER Earth Drill has been designed for user repair with ordinary hand tools. No special tools are required. Consult the appropriate section of the parts manual for instructions.

Service or technical consultation is available, free of charge, from the factory in Livingston, Texas. We will be pleased to help you with any problems or questions. Just write, fax, or call. Our hours are 8:00am - 4:30pm central time, Monday thru Friday.

Factory repair is available. If you return a part to the factory, please include the following information: Your name and return address, a description of the problem and payment or authorization to return the repaired item COD for the repair and shipping charges.

RETURNS...

Please call the factory for a return authorization. This will help to ensure that your parts are handled properly. Include your name and address, customer account #, invoice # under which the returned parts were ordered, and a brief description of the problem with the parts or the reason for returning them. Parts to be considered for warranty must be returned to the factory for inspection within 10 days after receipt of replacement parts. Be sure to prepay the shipping charges, we will not accept collect or COD packages.

Our mailing address...

LITTLE BEAVER, Inc.

2009 South Houston

P. O. Box 840

Livingston, Texas 77351



SAFETY ALERT SYMBOL



The symbol shown above is used to call your attention to instructions concerning your personal safety. **WATCH THIS SYMBOL** — It points out important safety precautions. It means — **ATTENTION! BECOME ALERT! YOUR PERSONAL SAFETY IS INVOLVED!**

Read the message that follows and be alert to the possibility of *Personal Injury or Death!*

WARNING: The Engine Exhaust from this product contains chemicals known to the State of California to cause cancer, birth defects or other reproductive harm.

1 YEAR LIMITED WARRANTY

For 1 year from purchase, LITTLE BEAVER, INC. will replace for the original purchaser, free of charge, any part or parts, found upon examination by any factory authorized service center, or by the factory at Livingston, Texas, to be defective in material or workmanship or both. If your equipment can not be repaired, it will be replaced. All transportation charges on parts submitted for replacement under this warranty must be borne by purchaser.

There is no other express warranty.

Implied warranties, including those of merchantability and fitness for a particular purpose, are limited to 1 year from purchase and to the extent permitted by law. Any and all implied warranties are excluded. This is the exclusive remedy and liability for consequential damages under any and all warranties are excluded to the extent exclusion is permitted by law.

*Notice: Engines are warranted by the manufacturer of the engine. See separate engine warranty enclosed.

MACHINE SERIAL NUMBER

There are two serial numbers for your hydraulic earth drill, one for the handle and one for the power source. The handle serial number is located on the bottom side of the handle. The power source serial number is located on the rear side of the hydraulic reservoir. For your convenience, when requiring service or parts information, refer to these numbers and your model numbers. Record the serial numbers, model numbers, engine make and date of purchase in the space provided below:

Handle Serial Number: _____ Power Source Serial Number: _____

Handle Model Number: _____ Power Source Model Number: _____

Engine Make: _____

Date of Purchase: _____



TABLE OF CONTENTS

OPERATORS MANUAL

Page #	
O-1	Safety Alert, Warranty and Machine Information
O-2	Table of Contents
O-3	Safety Instructions and Specifications
O-4	Maintenance and Lubrication Instructions
O-5	Wheel and Torque Tube Assembly
O-6 & 7	Operating Instructions
O-6	Handle and Auger Operation Information
O-7	Extension and Accessories
O-8	Decal Location
O-9	Troubleshooting

PARTS MANUAL

Page #	
P-1 & 2	Tank & Carrier Assembly
P-3	Pump, Filter and Sight Guage Assemblies
P-4	Torque Tube and Wires
P-5 & 6	One-Man Handle
P-7 & 8	Two-Man Handle
P-9 & 10	Anchor Handle
P-11 & 12	Auger Information
P-13	Extensions & Adaptors
	Hydraulic Notes
	Prices for Hydraulic Parts and Augers

Inside Back Cover...Torque Information and Conversion Chart



SAFETY INSTRUCTIONS



DANGER: Failure to observe safety instructions and reasonable safety practices can cause Property Damage, Serious Bodily Injury and/or Death. BE CAREFUL!! WATCH OUT FOR BYSTANDERS!!



DANGER: NEVER run engine inside building or enclosed area. Exhaust gases contain carbon monoxide, an odorless and deadly poison.



DANGER: NEVER drill holes where there is a possibility of underground power cables or other hazards. The exact location of underground services must be determined prior to drilling. Inadvertent severing of telephone, fiber optic or CATV transmission cable, or damage to sewer pipe is costly; RUPTURING OF GAS OR WATER LINES CAN CAUSE SERIOUS BODILY INJURY AND/OR DEATH. COMING INTO CONTACT WITH BURIED POWER LINES CAN CAUSE SERIOUS BODILY INJURY, SEVERE BURNS, AND/OR ELECTROCUTION. Call local utility companies or your local "One-Call" number at least 48 hours before digging and have underground utilities marked.



WARNING: Never use hands to search for leaks. Instead, use a piece of cardboard or wood. Escaping hydraulic fluid under pressure can have sufficient force to penetrate the skin, causing serious injury. Before disconnecting lines, be sure to relieve pressure. Before applying pressure, be sure connections are tight and fittings and hoses are not damaged.



WARNING: Augers are not to be used as anchoring devices.



CAUTION:

1. READ and understand this operator's manual and the operator's manual for the engine.
2. NEVER Operate drill without correctly installing torque tube.
3. NEVER Remove auger from hole while auger is turning.
4. NEVER Operate auger at less than full throttle.
5. NEVER Operate drill with damaged auger or other damaged or missing parts.
6. KEEP Hands, Feet and Clothing away from moving parts while engine is running.
7. KEEP All safety shields and devices in place.
8. MAKE Certain everyone is clear before operating the machine.
9. KEEP Leg pad against leg while drilling to maintain safe control.
10. WEAR SAFETY GLASSES.
11. KEEP Bystanders away from work area.
12. SHUT OFF Engine to adjust, service or clean the machine.

NOTICE

It is the responsibility of the contractor, owner and user to maintain and operate the Earth Drill in compliance with operating instructions provided. Observe all listed safety instructions and other reasonable safety practices. LITTLE BEAVER, INC. accepts no responsibility for damages to this machine, and other property damage and/or bodily injury due to careless or improper operations.

LITTLE BEAVER, INC. does not recommend or condone any modifications which would eliminate the torque tube.

LITTLE BEAVER, INC. does not recommend use of replacement hydraulic motors which would result in auger shaft torque greater than 400 ft.-lbs. If greater torque is required, please consult factory.

LITTLE BEAVER, INC. reserves the right to make changes in design and changes for improvements upon its product without imposing any obligation upon itself to install the same upon its products theretofore manufactured.

Your operators manual offers recommendations for prolonged and satisfactory service.

SPECIFICATIONS

11 HP Honda, 11 HP Briggs & Stratton OR 11 HP Wisconsin
6 GPM @ 2000 PSI
100 Micron Suction Screen
10 Micron Replaceable Return Line Filter
5 Gallon Hydraulic Reservoir



MAINTENANCE AND LUBRICATION INSTRUCTIONS

NOTE: All engines and hydraulic reservoirs are shipped WITHOUT oil.

ENGINE: The engine is shipped without oil or gasoline. Refer to the manufacturers instructions for proper procedures and recommended fluid.

HYDRAULIC FLUID AND FILTER: The hydraulic reservoir should be filled to the top of the sight gauge with hydraulic oil before attempting to start the engine. Most premium grade, mineral based oil with anti-wear (AW) and anti-foaming additives are suitable. The recommended fluid for normal temperature operation is ISO VG 46 grade fluid. In colder climates use ISO VG 32 grade and in warmer climates use ISO VG 68 grade fluid. The hydraulic oil and return line filter (Part # 30280) must be kept clean at all times, and should be changed after the first 15 hours of operation. The filter and oil should be changed every three months or after 100 hours of operation; whichever comes first.

NOTE: The hydraulic fluid and engine crankcase oil levels should be checked prior to each days use.

IMPORTANT: All nuts, fasteners, and fittings must be kept tightened. If the engine or tank mounting bolts are allowed to loosen, premature coupling and/or pump wear may result.



CAUTION: Escaping hydraulic fluid under pressure can have sufficient force to penetrate the skin, causing serious injury. Before disconnecting hydraulic lines, be sure to relieve pressure. Before applying pressure, be sure connections are tight and fittings, pipes and hoses are not damaged. Use a piece of cardboard or wood, rather than hands, to search for leaks. If injured by escaping fluid, see a doctor at once. Serious infection or reaction can develop if proper medical treatment is not administered immediately.



KEEP all hydraulic lines away from moving parts.

HYDRAULIC OIL LEAKAGE

If any hydraulic oil leakage is encountered, shut down the power source and relieve the hydraulic pressure by moving the throttle valve in both directions. Check and tighten the screw-on fittings on the end of each hose. If the leakage persists, it may be necessary to replace the associated hose assembly. If one of the Quick Disconnect fittings is the source of leakage, the quick disconnect coupling should be replaced. If the throttle valve is leaking around the spool (shaft), you may replace the seal kit (Part # 30275-2).

NOTE: To obtain maximum performance from power source, minimum hose size recommended is 3/8".

HYDRAULIC HOSE ASSEMBLY REPLACEMENT



WARNING: For power source serial numbers from H-0001 through H-3252, do not exceed the following maximum hose assembly lengths. Longer hose assemblies may allow the torque tube to uncouple, causing serious personal injury.

If replacement hose assemblies are required, the maximum overall length of the pressure/return hose assembly on the handle is 36". The maximum overall length of the pressure hose assembly on the power source is 74 1/4" and the maximum overall length of the return hose assembly on the power source is 68".

EXCESSIVE HEATING

Excessive heating is caused by placing too much down pressure on the auger which causes the oil pressure to reach relief pressure. Oil flowing over the relief valve generates the heat.

DECAL LOCATION

The decals which are provided with your machine are shown at the rear of this manual. The decals shown should be in the locations as described. If any of the decals are missing or illegible, order replacement decal kit # 30181-D# and install before operating the machine.



WHEEL ASSEMBLY

Attach a wheel to each end of the rear axle using a 3/4" flat washer and securing with a 1/8" x 1" cotter key. Attach the front wheel to the swivel bracket using one 3/4" x 5-1/2" cap screw, two spacers, and one 3/4" lock nut.

OPERATION

TORQUE TUBE ASSEMBLY



WARNING: Properly install torque tube to prevent serious injury from kick-back torque while drilling.



Figure 1



Figure 2

The torque tube consists of one end with a 1-1/2" square female fitting and a 1-1/4" square male fitting on the other end. Attach the larger female end of the torque tube to the power source bracket as shown in figure 1. Attach the other male end to the handle as shown in figure 2. Be sure to align the snap button with the mating hole provided and check to be sure the snap buttons are securely snapped into place.

BEFORE STARTING THE ENGINE, Be sure that:



DANGER: NEVER run engine inside building or enclosed area. Exhaust gases contain carbon monoxide, an odorless and deadly poison.

- 1.) Engine is properly prepared to Manufacturer's specifications. Note: Engines with "Oil Guard" protection must be filled with oil to full mark on dipstick or to point of overflowing to allow the engine to start.
- 2.) Hydraulic Reservoir is filled to top of sight gauge.
- 3.) The torque tube is properly attached.
- 4.) There is no auger connected to the handle.
- 5.) The Quick Disconnect fittings are correctly coupled.
- 6.) The Torque Tube has engaged the Kill Switch at the Power Source.

TO START THE ENGINE: Set the choke lever to the "ON" position and pull the starter rope. The engine should start after 2 or 3 pulls. Set the choke lever to the "OFF" position and allow the engine to warm-up for 2 or 3 minutes.



AFTER THE ENGINE HAS WARMED UP, Insert the auger into the drive adaptor on the bottom of the handle. Make sure the snap button and hole provided in the adaptor are aligned and the button snaps securely into place. Hold the handle so your left index finger and thumb can operate the throttle (pull with the index finger for forward rotation, push with the thumb for reverse). NOTE: ONLY use reverse to free the auger if it becomes lodged in the ground. Grasp the right handle bar with your right hand. Stand so the auger is straight up-and-down and is properly positioned to dig your hole (see figures 3 & 4). Note the safety instructions in this manual and on the machine's decals.



FIGURE 3



FIGURE 4

IMPORTANT: Keep the back as vertical as possible by bending the legs, as required, during the operating and lifting procedure.

ONE-MAN HANDLE

Always keep the leg pad against leg to maintain safe and stable control during operation.

TWO-MAN HANDLE

The operator controlling the throttle lever must alert the other operator prior to engaging the earth drill to ensure readiness. Both operators must distribute even pressure on the auger, as required, to maintain uniform drilling.



DANGER: NEVER drill holes where there is a possibility of underground power cables or other hazards. The exact location of underground services must be determined prior to drilling. Inadvertent severing of telephone, fiber optic or CATV transmission cable, or damage to sewer pipe is costly; RUPTURING OF GAS OR WATER LINES CAN CAUSE SERIOUS BODILY INJURY AND/OR DEATH. COMING INTO CONTACT WITH BURIED POWER LINES CAN CAUSE SERIOUS BODILY INJURY, SEVERE BURNS, AND/OR ELECTROCUTION. Call local utility companies or your local "One-Call" number at least 48 hours before digging and have underground utilities marked.



MAKE certain everyone is clear before operating the machine.



KEEP hands, feet and clothing away from moving parts while engine is running.

START THE AUGER TURNING By pulling the throttle lever in completely. Always allow the auger to turn at full speed and let it cut its way into the soil.

IMPORTANT: When digging in soft soil, hold up slightly on auger. In hard pan, apply pressure, but not enough to stall the auger or slow it down significantly. The auger works best when it turns at full speed.

IF THE AUGER STALLS repeatedly or slows down significantly; stop the auger by releasing throttle lever, slightly lift up on auger, start auger by pulling throttle lever, and allow the auger to turn at full speed while slowly lowering it to bottom of hole.



NEVER Remove auger from hole while auger is turning.

When the desired depth is reached, stop the auger by releasing the throttle lever. Then pull the auger completely out of the hole.

IMPORTANT: Keep the back as vertical as possible by bending the legs, as required, during the operation and lifting procedure.



AUGER EXTENSIONS

If greater hole depths are required, extensions may be used with the auger. After the auger has reached its maximum depth, stop the auger and disconnect the drive adaptor from the auger which remains in the hole. Connect the extension to the auger as shown in figure 5. Connect the drive adaptor to the extension and continue to dig the hole.



FIGURE 5

When the desired depth is reached, stop the auger and disconnect the drive adaptor from the extension then remove the extension(s) and auger from the hole.

 When working with cutting blade, point and auger flighting; be careful not to be cut by sharp edges.

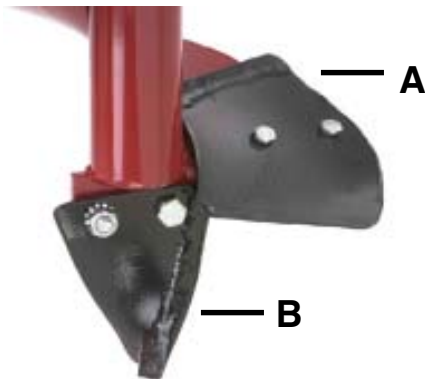

FIGURE 6

CUTTING BLADE

Check the cutting blade (Item A, Figure 6) on the auger frequently. If it becomes dull, it may be reversed to use the other cutting edge. If the outside of the blade wears even with the auger flighting, replace the blade or rebuild it with a hard surfacing rod. This is very important to reduce auger flighting wear and damage. The point (Item B, Figure 6) should be replaced when it loses its cutting shape.

ATTACHMENTS:

Several attachments are available for your LITTLE BEAVER Earth Drill; including both wet and dry type horizontal boring kits and a drill chuck adaptor which allows you to use a wood bit. Refer to the specific operating instructions supplied with the attachment. If these become lost or misplaced, replacements may be obtained from the factory.



DECAL LOCATION

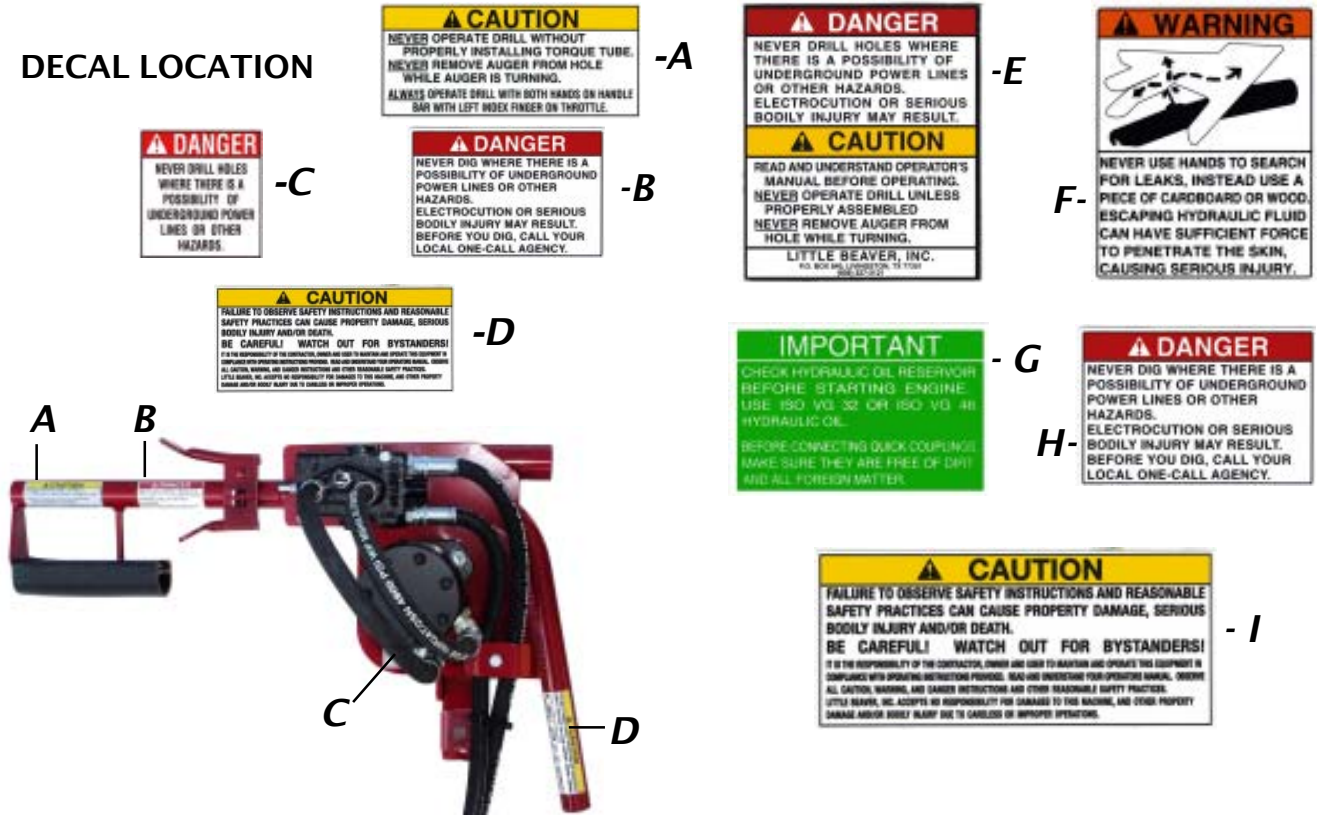

For Decal Kit, Order Part # 30181-D#





TROUBLESHOOTING

TROUBLE	CAUSE
Engine will not start	<ol style="list-style-type: none">1) Torque tube is not connected at power source2) Engine stop switch is in "off" or "O" position3) Low fuel level in gas tank4) Low oil level in "Oil Guard" or "Oil Alert" equipped engines5) Spark plug fouled
Starter rope pulls hard, with more resistance than usual	<ol style="list-style-type: none">1) Quick disconnect couplings are not fully connected. Push together and rotate collar 1/4 turn.
Cannot connect or disconnect auger	<ol style="list-style-type: none">1) Foreign matter clogging auger adaptor2) Spring and button in top of auger is bent or broken
Auger turns too slowly and will not dig	<ol style="list-style-type: none">1) Too much downward pressure or binding on side of hole. Hold back if necessary to allow auger to turn at full speed.2) Bent linkage between control level and valve. With engine off, ensure that neither lever touches handle bar when moved to full forward or reverse position.
Auger turns but will not dig	<ol style="list-style-type: none">1) Foreign matter collected around point2) Point or blade is dull3) Wrong blade type for soil condition. Contact your dealer or factory for Little Beaver carbide blade
Auger with extension will not dig	<ol style="list-style-type: none">1) Auger or extension bent or running out of line2) Number of extensions exceeds capacity of machine
Hydraulic oil and/or hoses overheats	<ol style="list-style-type: none">1) It is normal for the hoses and reservoir to be warm to the touch. If it is very hot, consult your dealer or factory.
Auger turns when engine idles	<ol style="list-style-type: none">1) Valve or linkage is binding. Do not use. Consult your dealer or factory.
Problems not listed in table	<ol style="list-style-type: none">1) Consult your dealer or factory.

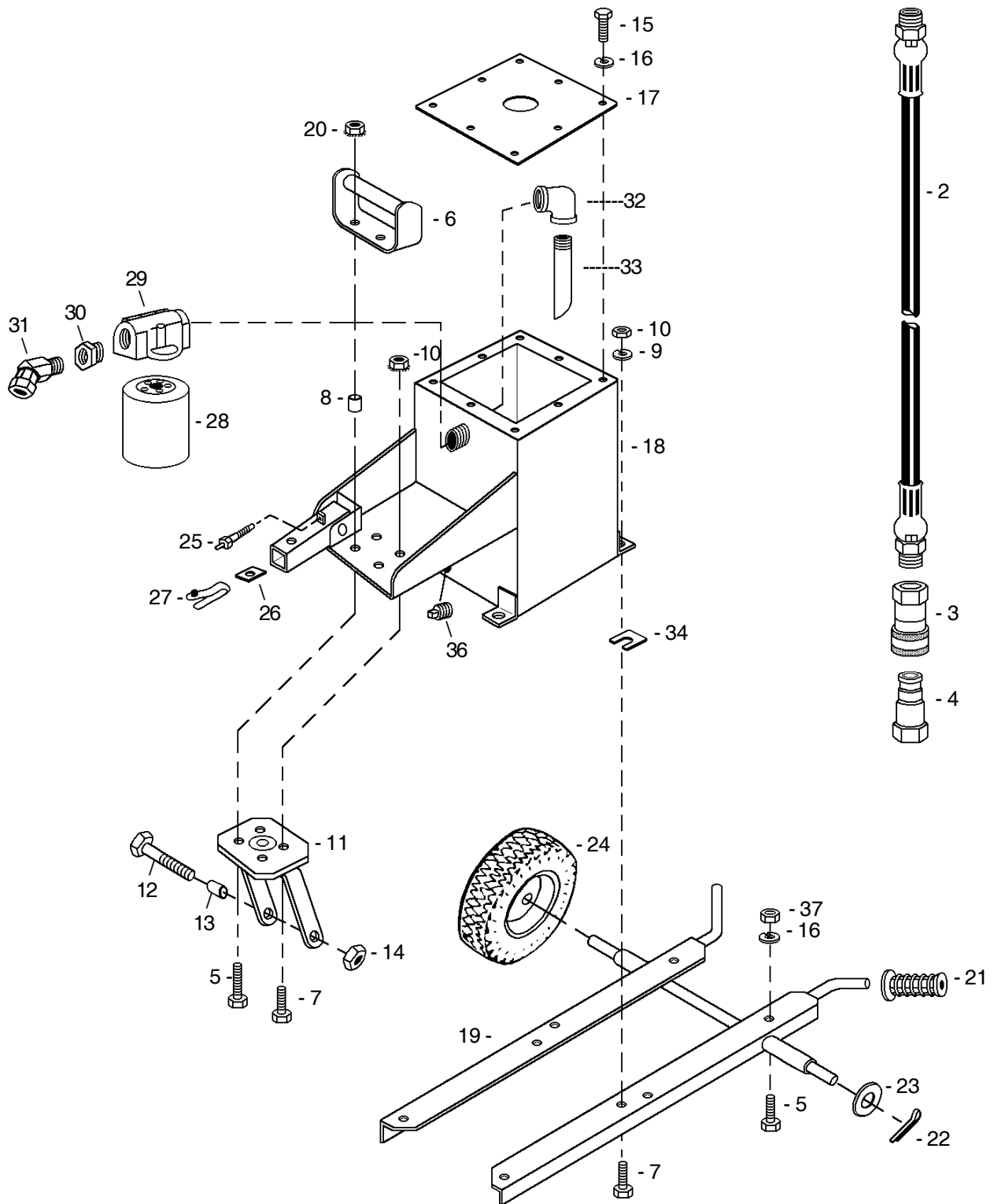

TANK AND CARRIER ASSEMBLY



ITEM	PART #	DESCRIPTION	QTY
		 WARNING: For power source serial numbers from H-0001 through H-3252, <u>do not</u> exceed the following maximum hose assembly lengths. Longer hose assemblies may allow the torque tube to uncouple, causing serious personal injury.	
2	30100	Pressure Hose - 74 1/4" max. overall length	1
2	30111	Return Hose - 68" max. overall length	1
3	30250-H*	Quick Disconnect Coupling, Female	1
4	30251-H*	Quick Disconnect Coupling, Male	1
5	3002-A	Cap Screw, Handle, Caster & Engine Mounting	6
6	30252	Handle, Front	1
7	3012-2	Screw - 3/8" x 1" GR 5	4
8	30198	Spacer, Handle - 5/16" x 5/8"	2
9	3012-3	Lock Washer - 3/8"	6
10	9027-KEP	Nut w/ Lock Washer - 3/8"	6
11	30253-A	Swivel Wheel Mount, Albion	1
12	30155-A	Axle, Swivel - 3/4" x 6" Hex Screw	1
13	30351	Spacer, Swivel Wheel - 3/4" ID x 1 1/8"	2
14	9096	Nut, Axle - 3/4"	1
15	3012-1T	Screw, Tank Top - 5/16"-18 x 3/4" GR 2	8
16	3002-C	Lock Washer - 5/16"	14
17	30254	Tank Top	1
18	30255	Tank	1
19	30256-H	Carrier	1
20	3002-KEP	Nut - 5/16"-18	2
21	30257	Handle Grip	2
22	30163	Cotter - Wheel 1/8" x 1"	2
23	30164	Washer, Wheel - 3/4" Flat	2
24	30348	Wheel, 12" - 3/4" Bore	3
25	3007-9	Kill Switch	1
26	9084-1	Spacer	1
27	9058	Spring & Button	1
28	30280***	Filter	1
29	30281	Filter Base	1
30	30282	Bushing	1
31	30283	Fitting	1
32	30312	Street Ell - 3/4"	1
33	30317	Diffuser, Oil Return Pipe	1
34	30313-11	Shim, 11 Ga - .120"	**
	30313-14	Shim, 14 Ga - .083"	**
	30313-16	Shim, 16 Ga - .065"	**
	30313-18	Shim, 18 Ga. - .049"	**
35	30313-1	Shim Kit - 2 Shims of each size (8 total)	1
36	30159	Magnet Plug	1
37	30318	Nut, Engine Mounting - 5/16"-18 Lock Nut	4

*Power Source with SN#1675 and lower order complete set shown above.

**Quantity and Size may vary.

***Replacement Filter cross reference numbers are as follows:

Zinga #AE10, Ripley #DP75210, Amback #S-28 or Fram #P1653A



PUMP, FILTER AND SIGHT GAUGE ASSEMBLIES

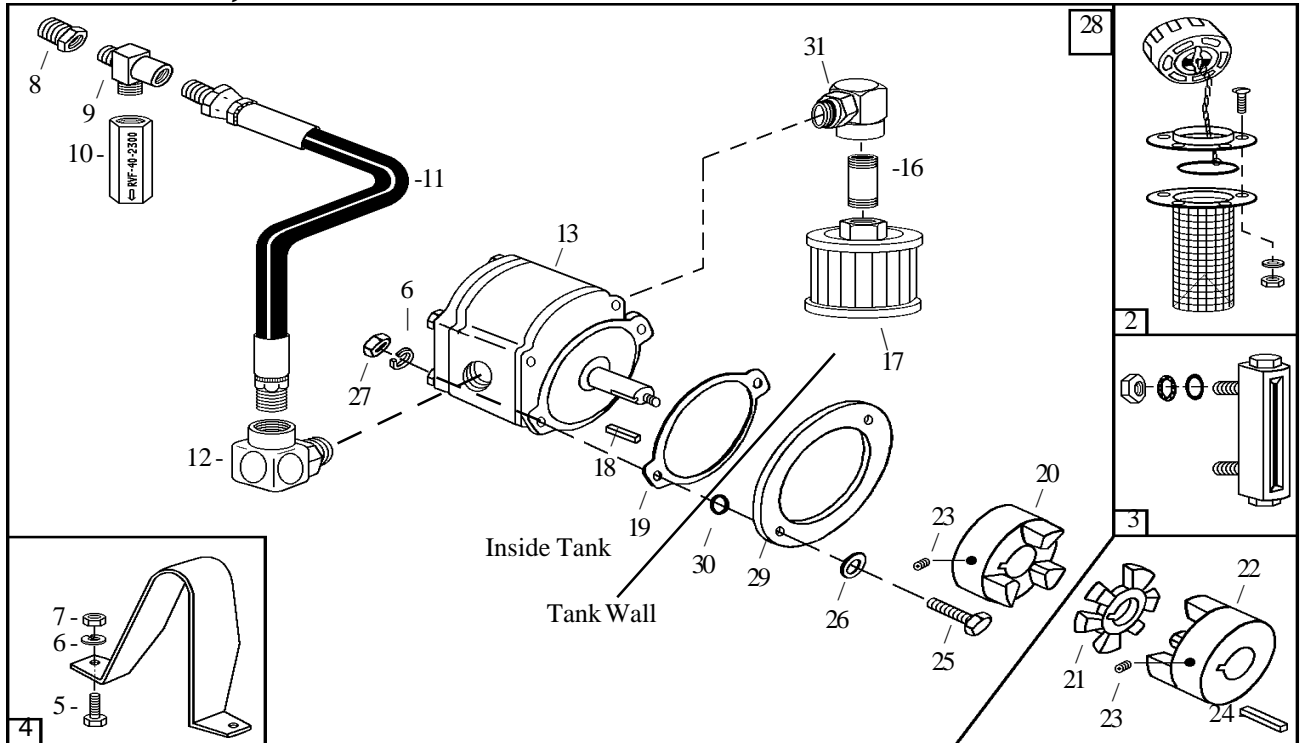

ITEM	PART #	DESCRIPTION	QTY
2	30260	Cap & Strainer Assembly	1
3	30262	Sight Guage Assembly	1
4	30172	Coupling Guard Assembly	1
5	3012-2	Screw - Guard 3/8" x 1"	2
6	3012-3	Lock Washer - Guard 3/8"	2
7	30154	Nut - Guard 3/8"	2
8	30315	Bushing #5406-8-6	1
9	30316	Fitting #5603-6-6-6	1
10	30270-R	Relief Valve	1
11	30291	Hose - Pump to Tank - 11"	1
12	30286	Fitting #6805-10-NWO	1
13	30263-D2	Dowty Pump with key, SAE-A 2-Bolt Flange	1
16	30310	Nipple 3/4" x 2 1/2"	2
17	30266	Suction Filter	1
18	4019	Key - Pump	1
19	30292-2	Gasket - Dowty Pump - SAE-A Flange (goes inside the tank)	1
20	30267-58	Coupling - Pump End, Dowty - 5/8" Bore	1
21	30269	Spider	1
22	30268	Coupling - Engine End 1" Bore (Honda & B&S)	1
	30268-W	Coupling - Engine End 1 1/8" Bore (Wisconsin)	1
23	30171	Set Screw	2
24	4081	Key - Engine End	1
25	30295	Bolt - 3/8" x 1 1/2" GR 5	2
26	30174	Washer - 3/8" with Neophreme Seal	2
27	30154	Lock Nut - 3/8" Nylon Insert	2
28	30263-D2A	Dowty Pump Assembly (2 bolt mounting)	1
	30314-D	Seal Kit, Dowty Pump	1
29	30293	Ring, Dowty Pump Tank	1
30	30294	O-Ring #110 (goes outside tank)	2
31	30298	Fitting, #6905-12-12-NWO	1



TORQUE TUBE ASSEMBLY

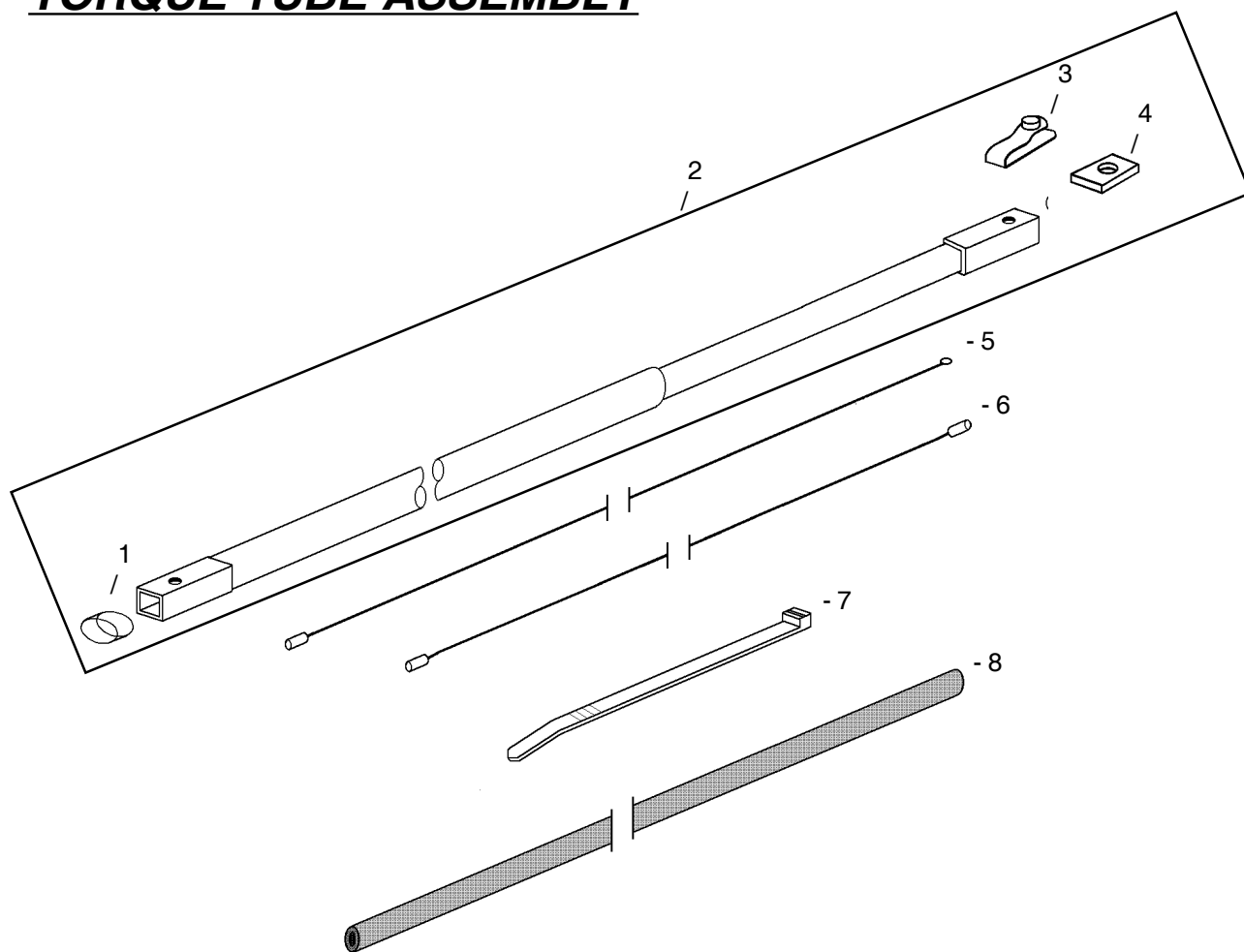

<u>ITEM</u>	<u>PART #</u>	<u>DESCRIPTION</u>	<u>QTY</u>
1	9058-1	Button Shield	1
2	9092-M	One piece Torque Tube	1
3	9058	Spring & Button	1
4	9084-1	Spacer	1
5	30200	Kill Switch Wire (BIC)	1
6	30200-HW	Kill Switch Wire (Honda & Wisconsin)	1
7	3007-5	Plastic Tie	5
8	30201	Wire Loom	1



ONE-MAN HANDLE

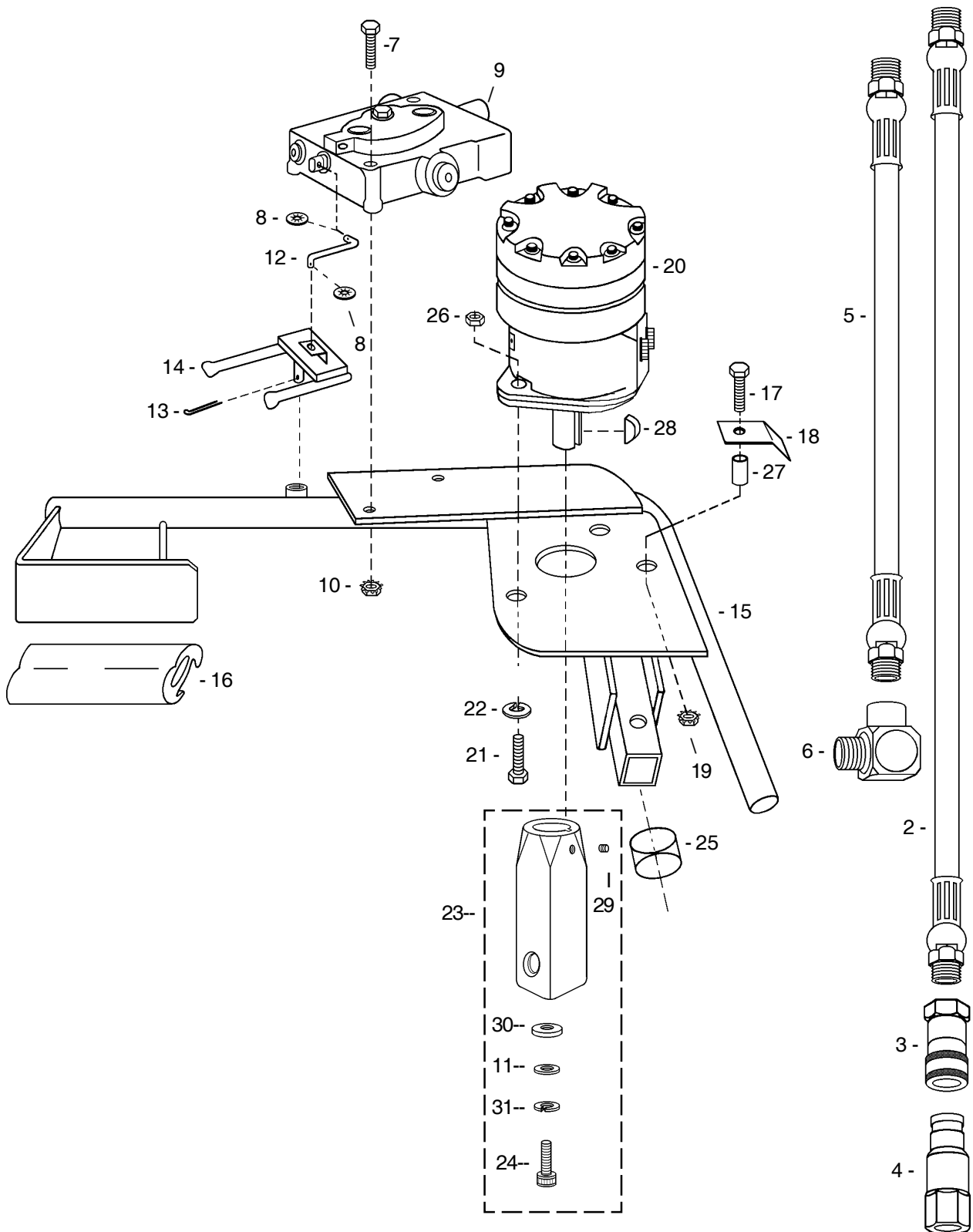

ONE-MAN HANDLE

<u>ITEM</u>	<u>PART #</u>	<u>DESCRIPTION</u>	<u>QTY</u>
	WARNING: For power source serial numbers from H-0001 through H-3252, <u>do not</u> exceed the following maximum hose assembly lengths. Longer hose assemblies may allow the torque tube to uncouple, causing serious personal injury.		
2	30102-A	Hose-Valve to Power/Valve to Return, 36" max. overall length	2
3	*30250-H	Disconnect Coupling-Female	1
4	*30251-H	Disconnect Coupling-Male	1
5	30115	Hose-Valve to Motor 15 1/2"	1
	30120-A	Hose-Valve to Motor 19 1/2"	1
		NOTE: SN H-163 & lower order Part #30103	
6	30296	Fitting-Pipe Swivel-Female (O-Ring)	2
	30287	Fitting-NPT	2
7	5076	Cap Screw 1/4" x 2" USS-Valve Mounting	2
8	30188	Pushnut, Locking Washer	2
9	30275	Throttle Valve	1
	30275-2	Seal Kit (Valve)	
10	9026-KEP	Nut 1/4" KEP (Nut w/Lock Washer)	2
11	10304	Washer, 1/4" Standard	1
12	30178-A	Throttle Linkage	1
13	30179	Cotter Key 3/32" x 5/8"	3
14	30180-A	Throttle Lever	1
15	30181-A	One-Man Handle ONLY	1
16	9034	Leg Pad	1
17	3010-9	Screw 5/16" x 2"-Hose Clamp	1
18	30183	Clamp-Hose	1
19	3002-KEP	Nut 5/16" KEP (Nut w/Lock Washer)	1
20	30191	Hydraulic Motor w/2 bolt flange-220 RPM (103-1035)	1
	30191-S2	Hydraulic Motor w/2 bolt flange-150 RPM (103-1036)	1
21	6532	Cap Screw 1/2" x 2" Gr 5 for 2-Bolt Motor	2
22	35312	Lock Washer 1/2"	2
23	30272	Adaptor, Heavy Duty, Hardware Included	1
24	30010	Screw, Socket Head 1/4"-20 x 1" with locking plug	1
25	9058-1	Button Shield	1
26	30158	Nut, Nylon Lock, 1/2"	2
27	30198	Spacer 5/16" x 5/8"-Hose Clamp	1
28	30182	Key	1
29	9021	Set Screw 1/4"-20 x 1/4"-Adaptor	1
30	10520	Washer, Williams, 3/8"	1
31	9025	Washer, Split Lock, 1/4"	1

30162-B Seal Kit (Motor # 103-XXXX-005/006)

30162-D Seal Kit (Motor # 103-XXXX-008, 009, 010)

*Power Source with SN#1675 and lower order complete set shown as above.

*Handle SN#5562 and lower order CO-2BF# as replacements.





TWO-MAN HANDLE

WARNING: For power source serial numbers from H-0001 through H-3252, do not exceed the following maximum hose assembly lengths. Longer hose assemblies may allow the torque tube to uncouple, causing serious personal injury.

ITEM	PART #	DESCRIPTION	QTY
2	30102-A	Hose-Valve to Power/Valve to Return, 36" max. overall length	2
3	*30250-H	Disconnect Coupling-Female	1
4	*30251-H	Disconnect Coupling-Male	1
5	30120-A2	Hose-Valve to Motor 24"	1
	30120-L	Hose-Valve to Motor 22 1/2"	1
		NOTE: SN H-163 & lower order Part #30105	
6	30296	Fitting-Pipe Swivel-Female (O-Ring)	2
	30287	Fitting, NPT	2
7	30275	Throttle Valve	1
	30275-2	Seal Kit (Valve)	
8	5076	Cap Screw 1/4" x 2" USS GR 5	2
9	9026-KEP	Nut 1/4" KEP (Nut w/ Lock Washer)	2
10	10304	Washer, 1/4", Standard Flat	1
11	30179	Cotter Key 3/32" x 5/8"	1
12	30180-A	Throttle Lever	1
13	30190	Two-Man Handle-Spider	1
14	3002	Bolt 5/16" x 1 1/2" USS GR 2-Hose Bracket	1
15	30183	Clamp-Hose	1
16	30188	Pushnut, Locking Washer	2
17	3002-KEP	Nut 5/16" KEP (Nut w/ Lock Washer)	7
18	30191	Hydraulic Motor w/ 2 bolt flange-220 RPM (103-1035)	1
	30191-S2	Hydraulic Motor w/ 2 bolt flange-150 RPM (103-1036)	1
	30278	Hydraulic Motor w/ 2 bolt flange-60 RPM (101-1040)	1
19	6532	Bolt 1/2" X 2" GR 5-Motor Mounting	2
20	35312	Lock Washer 1/2"	2
21	30272	Adaptor, Heavy Duty, hardware included	1
22	30010	Cap Screw 1/4"-20 x 1" w/Locking Plug	1
23	30271-A	Handle-Hose Anchor 18"	1
24	30178-A	Throttle Linkage	1
25	30273-A	Handle-Throttle Mount 18"	1
26	30274-A	Handle-Bare 18"	2
27	3010-9	Screw 5/16" x 2" USS GR 2-Handle	4
28	30198	Spacer 5/16" x 5/8"-Hose Clamp	1
29	9058-1	Button Shield	2
30	30158	Nut, Nylon Lock, 1/2"	2
31	30182	Key	1
32	30194	Handle Grip-Two-Man Handle	4
33	9021	Set Screw-Adaptor	1
34	10520	Washer, Williams, 3/8"	1
35	9025	Washer, Split Lock, 1/4"	1

30162-B Seal Kit (Motor # 103-XXXX-005/006)

30162-D Seal Kit (Motor # 103-XXXX-008, 009, 010)

*Power Source with SN#1675 and lower order complete set shown as above.

*Handle SN# 5562 and lower order CO-2BF# as replacements.



ANCHOR HANDLE

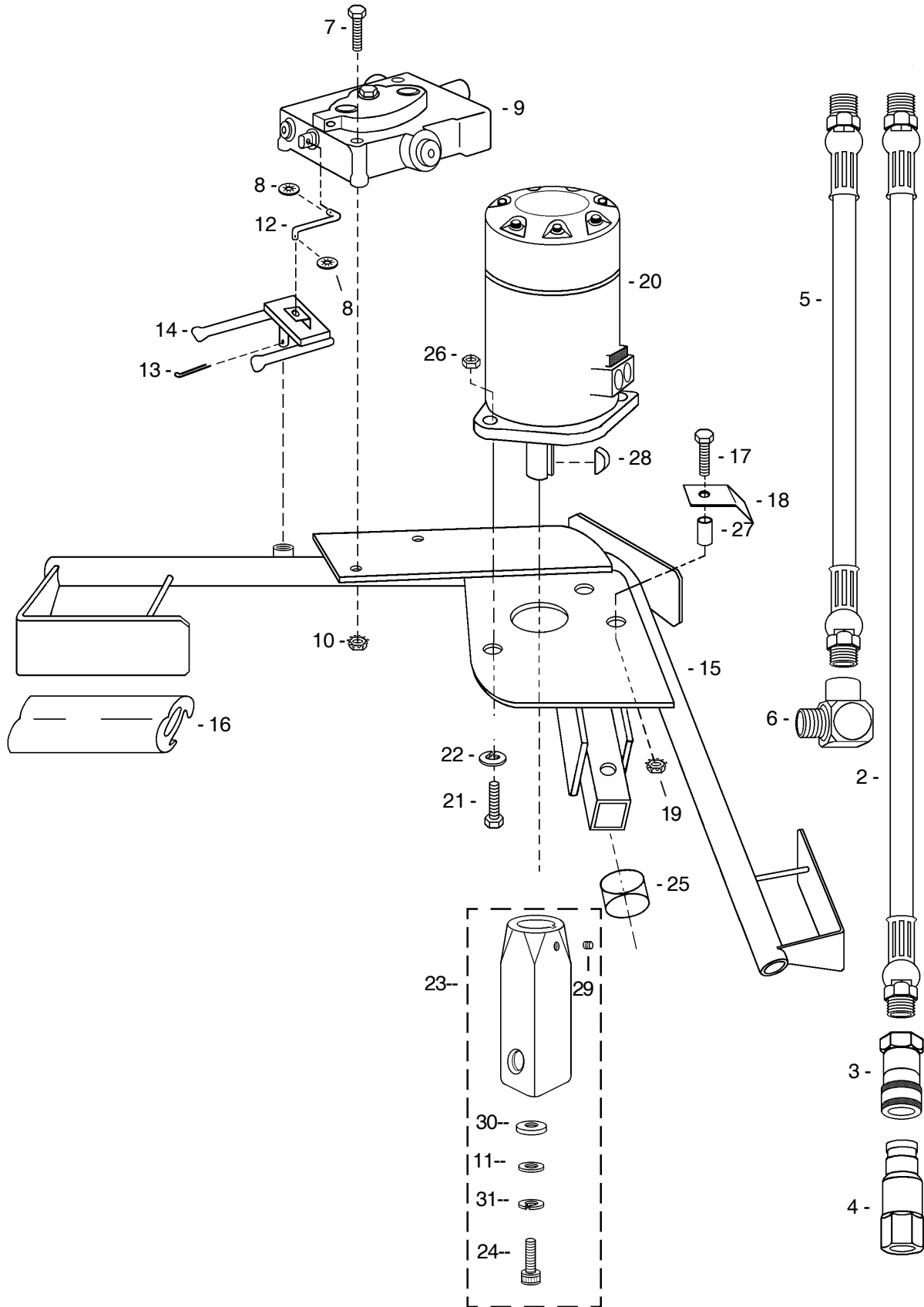

ANCHOR HANDLE

ITEM	PART #	DESCRIPTION	QTY
	WARNING: For power source serial numbers from H-0001 through H-3252, <u>do not</u> exceed the following maximum hose assembly lengths. Longer hose assemblies may allow the torque tube to uncouple, causing serious personal injury.		
2	30102-A	Hose-Valve to Power/Valve to Return, 36" max. overall length	2
3	**30250-H	Disconnect Coupling-Female	1
4	**30251-H	Disconnect Coupling-Male	1
5	30115	Hose-Valve to Motor 15 1/2"	1
	30120-A	Hose-Valve to Motor 19 1/2"	1
		NOTE: SN#163 & lower order Part #30103	
6	30296	Fitting-Female (O-Ring)	2
	30287	Fitting, NPT	2
7	5076	Cap Screw 1/4" x 2" USS GR 5-Valve Mounting	2
8	30188	Pushnut, Locking Washer	2
9	30275	Throttle Valve	1
	30275-2	Seal Kit (Valve)	1
10	9026	Nut 1/4" KEP (Nut w/ Lock Washer)	2
11	10304	Washer, 1/4" Standard	1
12	30178-A	Throttle Linkage	1
13	30179	Cotter Key 3/32" x 5/8"	1
14	30180-A	Throttle Lever	1
15	30276-A	Anchor Handle ONLY	1
16	9034	Leg Pad	3
17	3010-9	Set Screw 5/16" x 2" GR 2-Hose Clamp	1
18	30183	Clamp-Hose	1
19	3002-KEP	Nut 5/16" KEP (Nut w/ Lock Washer)	1
20	30278	Hydraulic Motor w/ 2 bolt flange-60 RPM (101-1040)	1
	30191-S2	Hydraulic Motor w/ 2 bolt flange-150 RPM (103-1035)	1
	30191	Hydraulic Motor w/ 2 bolt flange-220 RPM (103-1036)	1
21	6532	Bolt, 1/2" x 2" GR 5-MotorMounting	2
22	35312	Lock Washer 1/2"	2
23	30272	Adaptor, Heavy Duty, includes hardware	1
24	30010	Screw, Socket Head, 1/4"-20 x 1" with locking plug	1
25	9058-1	Button Shield	1
26	30158	Nut, Nylon Lock, 1/2"	2
27	30198	Spacer 5/16" x 5/8"	1
28	30182	Key	1
29	9021	Set Screw-Adaptor	1
30	10520	Washer, Williams, 3/8"	1
31	9025	Washer, Split Lock, 1/4"	1
	*30161	Seal Kit 60023 (Motor # 101-XXXX-007)	
	*30161-A	Seal Kit 60036 (Motor # 101-XXXX-005)	
	30162-B	Seal Kit (Motor # 103-XXXX-005/006)	
	30162-D	Seal Kit (Motor # 103-XXXX-008, 009, 010)	

*When ordering Flange or Seal Kit, you must specify motor serial number in order to obtain correct parts.

**Power Source with SN#1675 and lower order complete set as shown above.

*Handle SN#5562 and lower must order CO-2BF# as replacements



AUGERS & ACCESSORIES

STANDARD AUGER

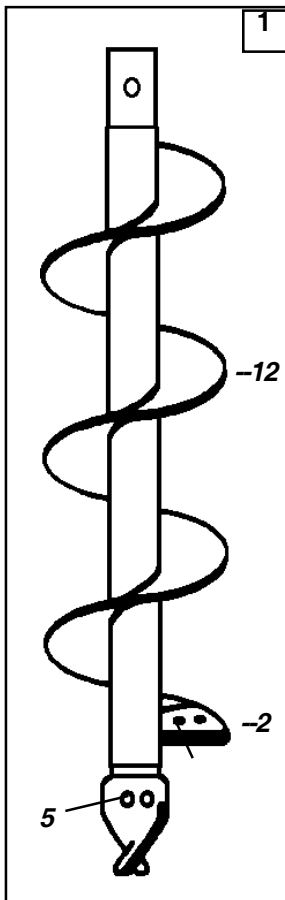

<u>ITEM</u>	<u>PART#</u>	<u>DESCRIPTION</u>
1	1.5X42-SSS	1-1/2" X 42" Auger, Snap-on with Screw-on Point
	2.5X42B	2-1/2" X 42" Bucket Auger, Snap-on
	2.5X42SP	2-1/2" x 42" Spiral Barrel Auger (Soil Sampling)
	2X36-SSS	2" X 36" Auger, Snap-on with Screw-on Point
	2X42-SSS	2" X 42" Auger, Snap-on with Screw-on Point
	3X36-SSS	3" X 36" Auger, Snap-on with Screw-on Point
	3X42-SSS	3" X 42" Auger, Snap-on with Screw-on Point
	4X36-SSS	4" X 36" Auger, Snap-on
	4X42-SSS	4" X 42" Auger, Snap-on
	5X36-SSS	5" X 36" Auger, Snap-on
	5X42-SSS	5" X 42" Auger, Snap-on
	6X36-SSS	6" X 36" Auger, Snap-on
	6X42-SSS	6" X 42" Auger, Snap-on
	7X36-SSS	7" X 36" Auger, Snap-on
	7X42-SSS	7" X 42" Auger, Snap-on
	8X36-SSS	8" X 36" Auger, Snap-on
	8X42-SSS	8" X 42" Auger, Snap-on
	9X36-SSS	9" X 36" Auger, Snap-on
	9X42-SSS	9" X 42" Auger, Snap-on
	10X36-SSS	10" X 36" Auger, Snap-on
	10X42-SSS	10" X 42" Auger, Snap-on
	12X36-SSS	12" X 36" Auger, Snap-on
	12X42-SSS	12" X 42" Auger, Snap-on
	14X36-SSS	14" X 36" Auger, Snap-on
	14X42-SSS	14" X 42" Auger, Snap-on
	16X36-SSS	16" X 36" Auger, Snap-on
	16X36-SSSF	16" X 36" Auger, Snap-on, Full Flighted
	16X42-SSSF	16" X 42" Auger, Snap-on, Full Flighted
2	9023-4	Blade for 4" & 5" Augers
	9023-6	Blade for 6" & 7" Augers
	9023-8	Blade for 8" Augers
	9023-9	Blade for 9" & 10" Augers
	9023-12	Blade for 12" Augers
	9023-14	Blade for 14" Augers
	9023-16	Blade for 16" Augers
3	9027	Point, Standard, Fits 4" thru 12" Augers
	9027-16	Point, Standard, Fits 14" and 16" Augers
4	9058	Spring & Button
5	9023-S4	Cap Screw & Nut w/Lockwasher, 4" thru 8" Blades
	9023-S9	Cap Screw & Nut w/Lockwasher, 9" thru 10" Blades
	9023-S12	Cap Screw & Nut w/Lockwasher, 12" Blades
	9023-S16	Cap Screw & Nut w/Lockwasher, 14" & 16" Blades
6	9027-7	Cap Screw & Nut w/Lockwasher, Standard Points



ITEM PART# DESCRIPTION

STANDARD AUGER WITH CARBIDE POINT 7

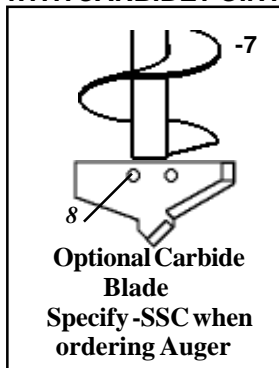

9023-C1.5	Blade, Screw-on, w/Carbide for 1-1/2" Augers
9023-C2	Blade, Screw-on, w/Carbide for 2: Augers
9023-C3	Blade w/Carbide for 3" Auger, Inc. Mtng. Bolts/Nuts
9023-C4	Blade w/Carbide for 4" Auger, " " "
9023-C5	Blade w/Carbide for 5" Auger, " " "
9023-C6	Blade w/Carbide for 6" Auger, " " "
9023-C7	Blade w/Carbide for 7" Auger, " " "
9023-C8	Blade w/Carbide for 8" Auger, " " "
9023-C9	Blade w/Carbide for 9" Auger, " " "
9023-C10	Blade w/Carbide for 10" Auger, " " "
9023-C12	Blade w/Carbide for 12" Auger, " " "

8 9027-8S Cap Screw & Lock Nut for Carbides (2 ea.)

PENGO AUGER

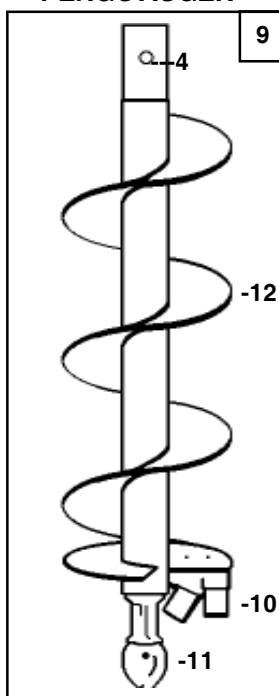

9	6X36-SSP	6" x 36" Snap-on Auger w/Pengo Point & Blade
	6X42-SSP	6" x 42" Snap-on Auger w/Pengo Point & Blade
	7X36-SSP	7" x 36" Snap-on Auger w/Pengo Point & Blade
	7X42-SSP	7" x 42" Snap-on Auger w/Pengo Point & Blade
	8X36-SSP	8" x 36" Snap-on Auger w/Pengo Point & Blade
	8X42-SSP	8" x 42" Snap-on Auger w/Pengo Point & Blade
	9X36-SSP	9" x 36" Snap-on Auger w/Pengo Point & Blade
	9X42-SSP	9" x 42" Snap-on Auger w/Pengo Point & Blade
	10X36-SSP	10" x 36" Snap-on Auger w/Pengo Point & Blade
	10X42-SSP	10" x 42" Snap-on Auger w/Pengo Point & Blade
	12X36-SSP	12" x 36" Snap-on Auger w/Pengo Point & Blade
	12X42-SSP	12" x 42" Snap-on Auger w/Pengo Point & Blade

10 9023-P35 Blade, Pengo #35 (1 per 6" & 7" Auger, 2 per 8"-12")
 9023-P35HS Blade, Pengo #35HFF Hardsurfaced (Both sides)
 9023-P1336 Blade, Pengo #1336 w/Carbide

11 9027-P Point, Pengo #SB25
 9027-PC Point, Pengo #SB-25C w/Carbide

12	FS-3	Flighting, replacement 3" x 37" or 60" Section
	FS-4	Flighting, 4" x 30" or 37" Section
	FS-5	Flighting, 5" x 30" or 37" Section
	FS-6	Flighting, 6" x 30" or 37" Section
	FS-7	Flighting, 7" x 30" or 37" Section
	FS-8	Flighting, 8" x 30" or 37" Section
	FS-9	Flighting, 9" x 30" or 37" Section
	FS-10	Flighting, 10" x 30" or 37" Section
	FS-12	Flighting, 12" x 37" Section
	FS-14	Flighting, 14" x 37" Section
	FS-16	Flighting, 16" x 16" Section

13 9062 Auger Top for 4" thru 10" Augers
 9062-H Auger Top for 12" thru 16" Augers

14 9062-1 Extension Bottom for 4" thru 10" Extensions
 9062-2 Extension Bottom for 12" thru 14" Extensions

AUGER REPAIR PARTS *Must be welded.*



ITEM PART# DESCRIPTION

EXTENSION

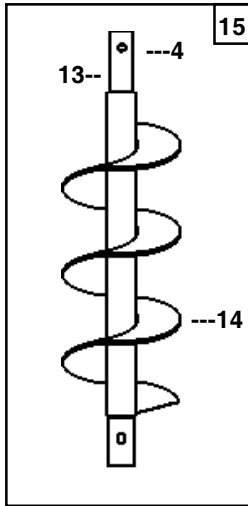

15

- 9054 36" Tube Type Snap-on Extension
- 9054-A 18" Tube Type Snap-on Extension
- 9054-S1.5X36 1-1/2" x 36" Screw-on Ext.(Must use Screw-on Agr)
- 9054-S2X36 2" x 36" Screw-on Ext.(Must use Screw-on Auger)
- 9054-S3X36 3" x 36" Screw-on Ext.(Must use Screw-on Auger)
- 9054-3X36 3" x 36" Snap-on Extension
- 9054-4X36 4" x 36" Snap-on Extension
- 9054-5X36 5" x 36" Snap-on Extension
- 9054-6X36 6" x 36" Snap-on Extension
- 9054-7X36 7" x 36" Snap-on Extension
- 9054-8X36 8" x 36" Snap-on Extension
- 9054-9X36 9" x 36" Snap-on Extension
- 9054-10X36 10" x 36" Snap-on Extension
- 9054-12X36 12" x 36" Snap-on Extension
- 9054-14X36 14" x 36" Snap-on Extension

HEX AUGER/EXTENSION

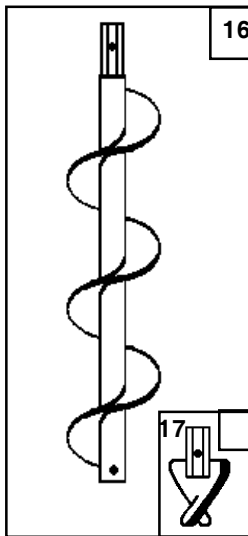

16

17

- 1.5X36-HSL 1-1/2" x 36" Auger/Extension, Hex, Less Point
 - 1.5X42-HSL 1-1/2" x 42" Auger/Extension, Hex, Less Point
 - 2X36-HSL 2" x 36" Auger/Extension, Hex, Less Point
 - 2X42-HSL 2" x 42" Auger/Extension, Hex, Less Point
 - 3X36-HSL 3" x 36" Auger/Extension, Hex, Less Point
 - 3X42-HSL 3" x 42" Auger/Extension, Hex, Less Point
-
- 9027-H1.5 Point, Hex, 1-1/2"
 - 9027-H2 Point, Hex, 2"
 - 9027-H3 Point, Hex, 3"
-
- 9041-2 Pin, Locking, 1-1/2" & 2" Hex Auger/Extensions
 - 9041-3 Pin, Locking, 3" Hex Auger/Extensions

9040 Spring Ball Plunger, (replace as needed)







ADAPTORS
Auger to Transmission

- 30272 Adaptor, Keyed
- 30272-HD Adaptor, Keyed, Heavy Duty
- 9051-GHAS Adaptor, Ground Hog to Keyed Adaptor
- 9061 Adaptor, Screw-on Auger to Keyed Adaptor
- 9061-H Adaptor, 1-1/2" & 2" Hex Auger to Keyed Adaptor
- 9061-H3 Adaptor, 3" Hex Auger to Keyed Adaptor
- 9061-A Adaptor, Drill Chuck to Keyed Adaptor

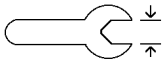

IMPORTANT: All nuts, fasteners, and fittings must be kept tightened. Refer to torque chart for proper assembly torque.

TORQUE INFORMATION

 TYPE SIZE	HEX HEAD		SOCKET		
	 GRADE 5	 GRADE 8	 WRENCH SIZE	 	 WRENCH SIZE
			inch		
No. 4	8 in lb	12 in lb	1/4"	12 in lb	3/32"
No. 6	16 in lb	23 in lb	5/16"	21 in lb	7/64"
No. 8	30 in lb	41 in lb	11/32"	42 in lb	9/64"
No.10	43 in lb	60 in lb	3/8"	60 in lb	5/32"
1/4"	8 ft lb	12 ft lb	7/16"	12 ft lb	3/16"
5/16"	17 ft lb	25 ft lb	1/2"	24 ft lb	1/4"
3/8"	30 ft lb	45 ft lb	9/16"	43 ft lb	5/16"
7/16"	50 ft lb	70 ft lb	5/8"	69 ft lb	3/8"
1/2"	75 ft lb	110 ft lb	3/4"	105 ft lb	3/8"
9/16"	110 ft lb	150 ft lb	13/16"	158 ft lb	----
5/8"	150 ft lb	220 ft lb	15/16"	195 ft lb	1/2"
3/4"	260 ft lb	380 ft lb	1-1/8"	353 ft lb	5/8"

HYDRAULIC FITTINGS

<u>SIZE</u>	<u>TORQUE</u>	<u>SIZE</u>	<u>TORQUE</u>
1/4 NPT	25 ft.lb.	7/16-20 SAE O-Ring	12 ft.lb.
3/8 NPT	50 ft.lb.	9/16-18 SAE O-Ring	20 ft.lb.
1/2 NPT	75 ft.lb.	3/4-16 SAE O-Ring	35 ft.lb.
3/4 NPT	110 ft.lb.	7/8-14 SAE O-Ring	50 ft.lb.
		1-1/16-12 SAE O-Ring	70 ft.lb.



**THINK
SAFETY
FIRST!**

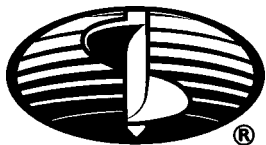

LITTLE BEAVER, INC.

P.O. BOX 840 • LIVINGSTON, TEXAS 77351

PH# 936/327-3121 • FAX# 936/327-4025